

# NS-101-D

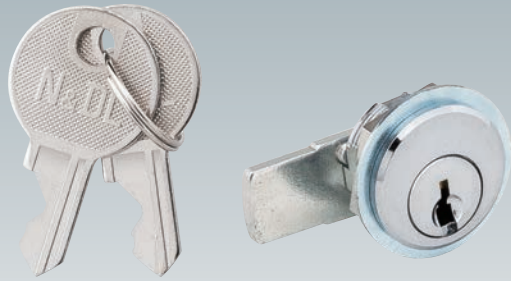

※写真および仕様図は標準仕様のものであります。  
Photo and Diagram indicate the standard model.



**特長**

- NS-100-1と比べて低価格品
- M18サイズの錠前
- レバー付き
- 筐体取り付けナットはレバーを取り付けたままで組み込み可能

**用途** ○分電盤、鋼製家具、小型機器など

**本体** □材質：亜鉛(ダイカスト)

□表面仕上げ：クロムメッキ

**キー** ○材質：真鍮

○表面仕上げ：ニッケルメッキ

**Feature** ●Low price product compared to NS-100-1.

●M18 size lock.

●Lever attached.

●Main body placement nut can be built-in with a lever installed.

**Use** ○Elec. distribution board, steel-made furniture, small equipment, etc.

**Body** □Material: Zinc alloy (Die casting).

□Surface treatment: Chrome plated.

**Key** ○Material: Brass.

○Surface treatment: Nickel plated.

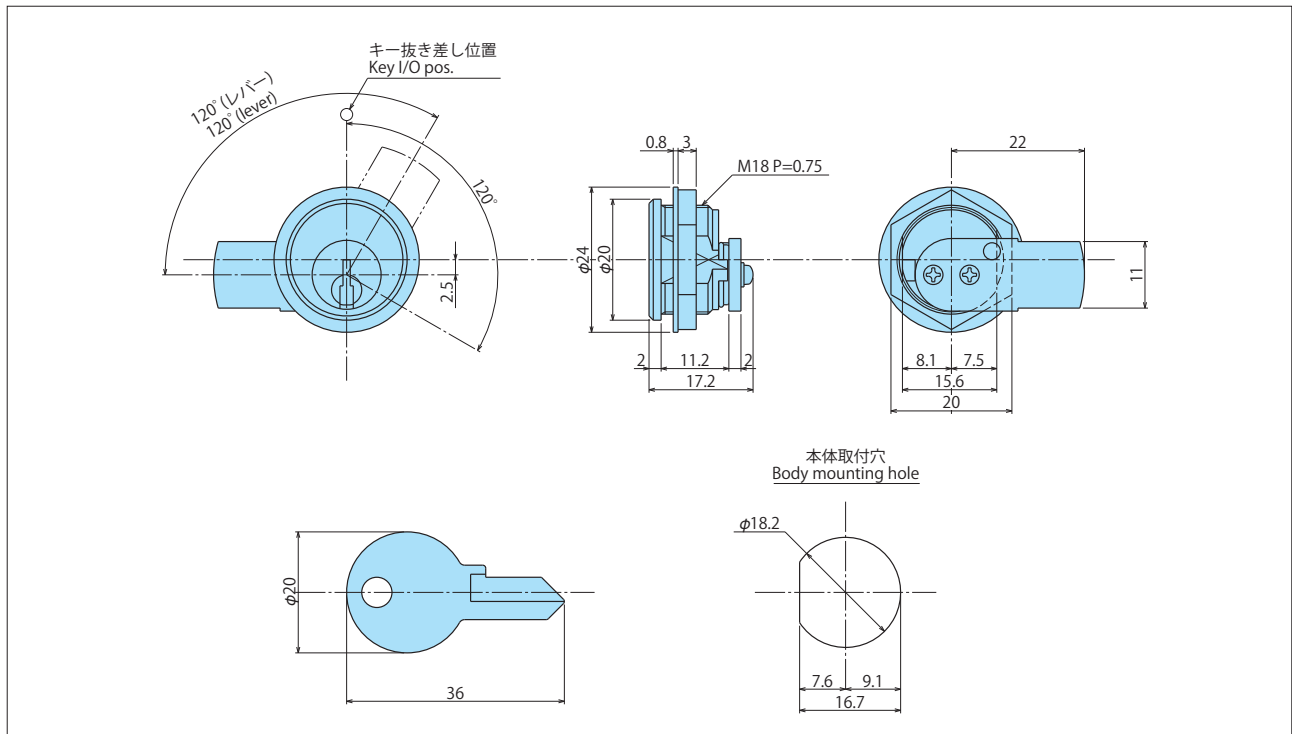

**仕様 Specifications**

鍵違い数 Key comb. No.	子鍵数 Indiv. Key	親鍵数 Master Key	キー回転角度 Key rot. ang.	キー抜き差し位置 Key I/O pos.	対応筐体厚(mm) Max. body thick. (mm)	本体重量(g) Body(g)	キー[2本](g) Key [w/2] (g)
同番 Same number	—	—	右120°(レバー左付き)(標準) 左120°(レバー右付き) R120°(std/lever at left) L120°(lever at right)	1ヶ所 1 pos.	~ 4	25	11